

HOME VENTILATION WITH HEAT RECOVERY

M-WRG-S ventilation unit (standard unit)



OPERATING INSTRUCTIONS

Part no. 5302-00-01 Week 08/2016 EN



Contents

1	Introduction	5
1.1	Notes on the operating instructions	5
1.2	Description	5
1.3	Target group	6
1.4	EC Declaration of Conformity	6
1.5	National technical approval (for Germany)	6
1.6	Nameplate	7
1.7	Technical data	7
1.7.1	Electrical connection	7
1.7.2	Dimensions and weight	7
1.7.3	Noise emission	7
1.7.4	Unit properties	7
1.7.5	Unit features	8
1.7.6	Filter	8
1.8	Storage	8
1.9	Environmentally-friendly disposal	8
1.10	Revision index	8
1.11	Explanation of the symbols used	8
2	Safety instructions	9
2.1	Hazard classification	9
2.2	Notes on using the ventilation units safely	9
2.3	Notes on using the ventilation units	10
2.4	Intended use	10
3	Warranty and liability	11
3.1	Warranty	11
3.2	Liability	11
4	Dimensions	11
5	Structure and function	12
5.1	Overview of the modules	12
5.1.1	Ventilation unit – cover attached	12
5.1.2	Ventilation unit – cover removed	12
5.1.3	Outer wall terminal	12
5.2	Description of the functions	13
5.2.1	How the M-WRG ventilation unit works	13
5.2.2	How the cross-flow plate heat exchanger works	14
6	Rules for correct usage	14
6.1	General	14
6.2	Operation in high atmospheric humidity	14
6.3	Operation at cold times of year	15
6.4	Filter	15
7	Controls on the ventilation unit	16
8	Starting up	16
8.1	Check ventilation unit before switching on for first time	16

8.2	Switch on the ventilation unit	16
8.3	Check position of air flaps	17
9	Operating the ventilation unit	18
9.1	Set ventilation level on stepping switch	18
9.2	Frost protection function	18
10	Filter maintenance	19
10.1	Choice of filter	19
10.2	Ordering filters	19
10.3	Filter change	19
10.3.1	Remove cover from ventilation unit	20
10.3.2	Remove filter	20
10.3.3	Insert new filters	21
10.3.4	Attach cover to ventilation unit	21
11	Cleaning	22
12	Troubleshooting	22





1 Introduction

1.1 Notes on the operating instructions

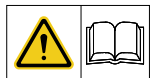

These original operating instructions contain important information that should be followed when setting up and using the M-WRG-S ventilation unit.

- ▶ Read all the instructions carefully before starting up the ventilation unit to avoid possible risks and mistakes.
- ▶ When assembly is complete, give these instructions to the home owner, caretaker or property manager.
- ▶ These instructions are part of the product. Keep the instructions in a safe place for future reference.

WARNING

- ▶ Follow ALL danger and warning instructions and notes on precautionary measures.
- ▶ Read section „2 Safety instructions“ on page 9 carefully.

1.2 Description

These instructions describe how to set up and operate the decentralised ventilation unit M-WRG-S (see Fig. 1).



Fig. 1: M-WRG-S ventilation unit

M-WRG-S stands for Meltem heat recovery standard unit. Home ventilation expertise extending back over 30 years has been incorporated into this product from Meltem Wärmerückgewinnung. Using windows for ventilation, particularly during periods of cold weather, is now a thing of the past.

This ventilation unit brings in outdoor air fully automatically, and heats it by recovering heat from the air that is extracted. Outdoor air and extract air are routed in separate ducts through a cross-flow plate heat exchanger (see section 5.2.2 on page 14). You save on heating costs, increase your living comfort and are kind to the environment by reducing CO₂ emissions. A filter also removes pollen, dust and other impurities from the outdoor air.

The ventilation units are designed for continuous operation and can be both surface-mounted and flush-mounted. The ventilation units are low-maintenance, but **regular filter changes** are important.

A stepping switch on the M-WRG-S ventilation unit is used to set three different power levels and a time-limited intensive ventilation level. It therefore allows you to adapt the air flow to your needs.

1.3 Target group

These operating instructions are intended for users of the ventilation unit. They do not require any special prior knowledge.

1.4 EC Declaration of Conformity

The ventilation unit described below

Type: M-WRG-S
Part number: 5010

manufactured by

Meltem Wärmerückgewinnung GmbH & Co. KG
Am Hartholz 4
82239 Alling

conforms to the regulations and standards listed in the EC Declaration of Conformity provided.

1.5 National technical approval (for Germany)

A valid national technical approval from the Deutsches Institut für Bautechnik (DIBt) must be obtained for the ventilation unit before it is installed in Germany. This approval can be provided upon request or can be downloaded from our website at www.meltem.com/waermerueckgewinnung/downloads/ (see also the QR code on the back page of these instructions).

The approval number is Z-51.3-138 (see item 1 in Fig. 2).

- For installation outside Germany, the national regulations applicable in your country should be followed.

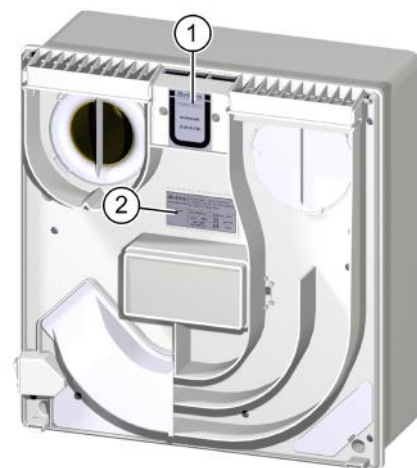

Fig. 2: Approval number and nameplate

1.6 Nameplate

You will find the nameplate on the intermediate plate on the inside of the housing (see item 2 in Fig. 2 on page 6).

1.7 Technical data

1.7.1 Electrical connection

Operating voltage	230 V AC
Mains frequency	50 Hz
Power consumption	3.8 - 34 W
Power consumption in relation to the air volume flow	0.17 W/m ³ /h (at 30 m ³ /h)
Maximum current consumption	0.16 A
Connecting cable	NYM-J 3 x 1.5 mm ²
IP rating	IPX1 IPX4 with protective cap on mains switch (optional, must be installed at the factory)

1.7.2 Dimensions and weight

Unit dimensions excluding air connectors (see also Fig. 3 on page 11)	409 mm x 388 mm x 196 mm (H x W x D)
Visible unit depth when surface-mounted	196 mm
Visible unit depth when flush-mounted	66 mm
Outdoor air/exhaust air connectors	DN 100
Weight	Approx. 8.1 kg

1.7.3 Noise emission

Sound pressure level $L_{p,A}$ flush-mount	15.5 - 46.5 dB(A)/ A_{eq} 10 m ²
Sound pressure level $L_{p,A}$ surface-mount	19 - 46 dB(A)/ A_{eq} 10 m ²
Sound insulation $D_{n,e,w}$ flush-mount/surface-mount	50/50 dB

1.7.4 Unit properties

Air flow	15 - 100 m ³ /h
Heat recovery efficiency	Up to 76 %
Leakage	0.1 %

1.7.5 Unit features

Output control	3 levels + intensive ventilation level
Supply air/extract air fan	EC direct current motor, radial fan
Heat exchanger	Cross-flow plate heat exchanger
Filter change indicator (depends on the level of soiling of the filter)	Audible
Condensate drainage	Via exhaust air pipe, no condensate trap required
Fully automatic cover flap control when switching On / Off and if the power fails	Yes
Frost protection function	Yes

1.7.6 Filter

Designation	Filter class	Filter area
Standard filter	G4	0.36 m ²
Allergy filter (optional)	F7	0.32 m ²
Activated charcoal filter (optional)	M6	0.12 m ²

1.8 Storage

- ▶ Store the ventilation unit in its original packaging in a dry place where the temperature ranges between 0 °C and +40 °C.

1.9 Environmentally-friendly disposal

The ventilation units must not be disposed of in the residual waste bin.



- ▶ Dispose of the ventilation unit in accordance with the electronic waste disposal regulations that apply on site.

1.10 Revision index

Edition	Manual	Date
3 rd edition	Operating instructions M-WRG-S ventilation unit	Week 08/2016 EN

1.11 Explanation of the symbols used

- ▶ This symbol indicates an action to be taken.
- This symbol indicates a list.

2 Safety instructions

This manual contains notes that you must follow for your own personal safety and to avoid injury and damage to property. They are highlighted by warning triangles and are shown as follows according to the level of danger.

2.1 Hazard classification

DANGER

The signal word designates a hazard with a **high** degree of risk which, if it is not avoided, will result in death or severe injury.

WARNING

The signal word designates a hazard with a **medium** degree of risk which, if it is not avoided, will result in death or severe injury.

CAUTION

The signal word designates a hazard with a **low** degree of risk which, if it is not avoided, could result in minor or moderate injury.

NOTE

A note as used in this manual contains important information about the product or about a part of the manual to which particular attention should be paid.

2.2 Notes on using the ventilation units safely

WARNING

— **Fire protection**

- ▶ Follow the requirements of the national technical approval from the Deutsches Institut für Bautechnik (DIBt), approval number Z-51.3-138, when planning and installing the unit.

— **Operation with fireplaces**

- ▶ An additional safety device (underpressure or differential pressure monitor) is needed to monitor operation when M-WRG ventilation units are used in conjunction with fireplaces.
- ▶ Follow the requirements of the German Fire Code (FeuVo) when planning and installing the unit.
- ▶ Contact the local chimney sweep before the end of the planning phase.
- ▶ Have the chimney sweep approve the operation of the ventilation unit.

— **Installation in wet areas**

The following rules from DIN VDE 0100-701/702 (IEC 60364-7-701) apply to installation in wet areas:

- Protection zone 0 and 1: The unit must NOT be installed in these areas.
- Protection zone 2: The unit may be installed in this area if the mains switch is covered with a protective cap. The protective cap must be installed at the factory.

- ▶ You will need to include the mains switch protective cap (M-WRG-SN, part no. 5430) when you order the ventilation unit.
- Other zone: The unit may be installed in this area.
- **Build-up of icicles and ice patches at low temperatures**
The heat recovery process in our ventilation units causes condensation. This condensation is dissipated to the outside via the exhaust air pipe. When external temperatures drop below 0 °C this can cause a build-up of icicles at the outer wall terminals and ice patches on the ground.

 **CAUTION**

- **Starting and using the ventilation unit**
 - ▶ Do not start up the ventilation unit until it is fully installed.
 - ▶ Always make sure that the cover is closed and locked in place before using the ventilation unit.

2.3 Notes on using the ventilation units

- This unit may be used by children from 8 years old and by persons of restricted physical, sensory or mental abilities or persons lacking experience and knowledge if they are supervised or have been instructed in how to use the unit safely and understand the associated hazards. Do not allow children to play with the unit. Cleaning and user maintenance must not be carried out by children unless they are supervised.
 - ▶ Follow the regulations applicable in your country concerning the age from which people may be permitted to operate the ventilation unit.
- The ventilation unit must always be freely accessible for operation and maintenance.
 - ▶ Make sure that the ventilation unit is not blocked, obstructed or covered when the room is subsequently decorated and furnished, otherwise it cannot be used and it will not be possible to replace the filter.
 - ▶ Make sure that the supply and extract air openings are not blocked, obstructed or covered when the room is subsequently decorated and furnished.

2.4 Intended use

- The ventilation unit is intended for supplying air to and extracting air from living and recreation rooms (bedrooms, playrooms, living rooms, bathrooms, basement workshops, offices, consulting rooms, etc.). The ventilation unit is installed in a perpendicular position in the external wall. Any different or more extensive usage will be regarded as contrary to the intended use.
- The intended use also includes compliance with all the notes in the operating instructions.
- The ventilation unit must not be operated without a filter.
- The ventilation unit's functions may be impaired or the unit may be damaged in rooms with a lot of dust (e.g. model-making) or corrosive gas emissions (e.g. blueprint shop, cleaning).
- For any use contrary to the intended use, Meltem Wärmerückgewinnung GmbH & Co. KG shall accept no liability for any damage that may occur and offers no warranty that the components will work perfectly and correctly.

3 Warranty and liability

3.1 Warranty

The following cases shall invalidate the warranty:

- The installation kit was not installed as described in the installation manual.
- The ventilation unit was not installed as described in the installation manual.
- Genuine Meltem parts were not replaced with genuine parts.
- Unapproved changes were made to the installation kit or ventilation unit.
- Repairs were carried out incorrectly.
- The ventilation unit was operated without a filter.
- The warranty does not cover wearing parts such as filters.

3.2 Liability

The manufacturer's liability shall not apply in the following cases:

- The installation kit was not installed as described in the installation manual.
- The ventilation unit was not installed as described in the installation manual.
- Genuine Meltem parts were not replaced with genuine parts.
- Unapproved changes were made to the installation kit or ventilation unit.
- Repairs were carried out incorrectly.
- The ventilation unit was operated without a filter.

4 Dimensions

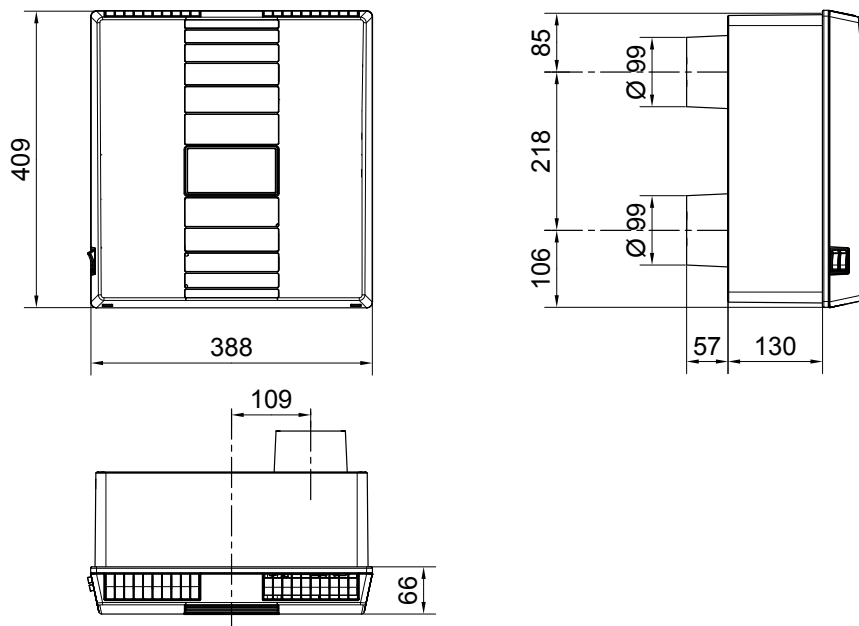

Fig. 3: Dimensions of the M-WRG-S ventilation unit, in millimetres

5 Structure and function

5.1 Overview of the modules

5.1.1 Ventilation unit – cover attached

Item	Designation
1	Housing
2	Cover
3	Stepping switch for three power levels + intensive ventilation level
4	Mains switch

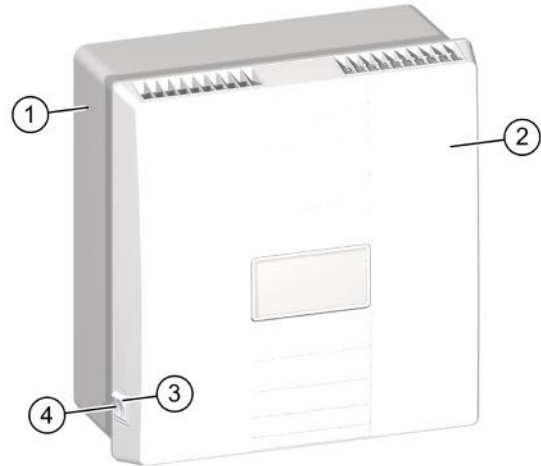

Fig. 4: Ventilation unit – cover attached

5.1.2 Ventilation unit – cover removed

Item	Designation
1	Supply air opening with air flap
2	Supply air filter with filter cover
3	Intermediate plate
4	Network connection cover
5	Supply air hood
6	Extract air filter with filter ring
7	Extract air opening with air flap

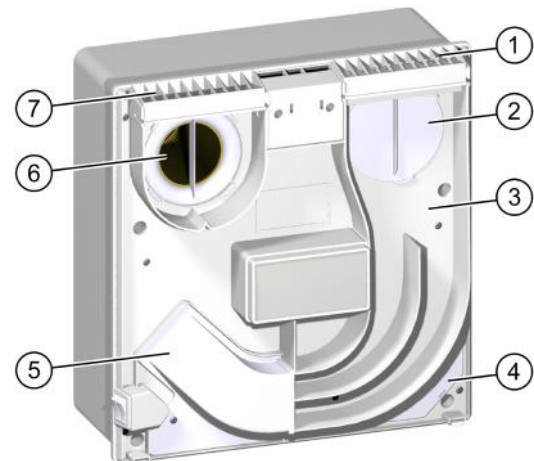

Fig. 5: Ventilation unit – cover removed

5.1.3 Outer wall terminal

Item	Designation
1	Opening for drawing in outdoor air
2	Opening for blowing out exhaust air

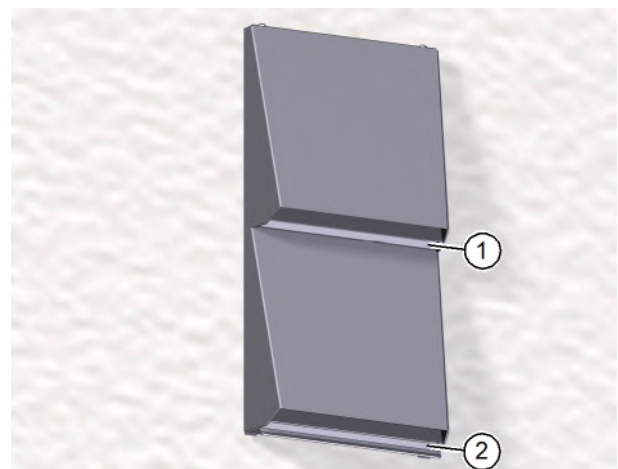

Fig. 6: Outer wall terminal

5.2 Description of the functions

5.2.1 How the M-WRG ventilation unit works

The supply air fan (item 5 in Fig. 8) transports outdoor air (item 7 in Fig. 7) through the supply air filter (item 2 in Fig. 8) and cross-flow plate heat exchanger (item 3 in Fig. 8) into the interior as supply air (item 4 in Fig. 7). The extract air fan (item 4 in Fig. 8) extracts the extract air (item 3 in Fig. 7) from the interior. In the extract air filter (item 1 in Fig. 8), the extract air is cleaned, guided through the cross-flow plate heat exchanger and carried outside as exhaust air (item 8 in Fig. 7). The supply air and extract air fans each transport the same volume of air. The pressure in the interior remains practically constant.

Item	Designation
1	M-WRG ventilation unit
2	Internal wall side
3	Extract air
4	Supply air
5	External wall side
6	Outer wall terminal
7	Outdoor air
8	Exhaust air

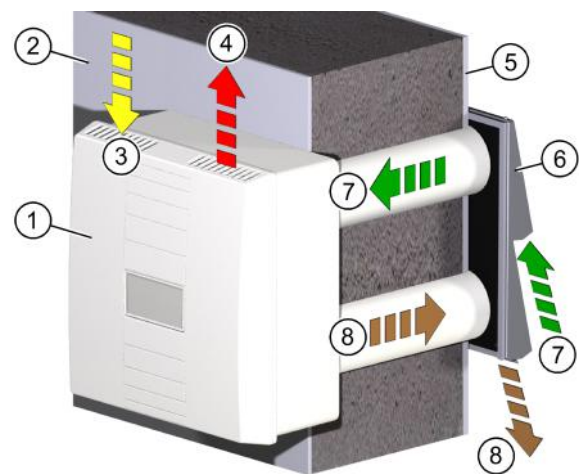

Fig. 7: How the ventilation unit works

Item	Designation
1	Extract air filter
2	Supply air filter
3	Cross-flow plate heat exchanger
4	Extract air fan
5	Supply air fan

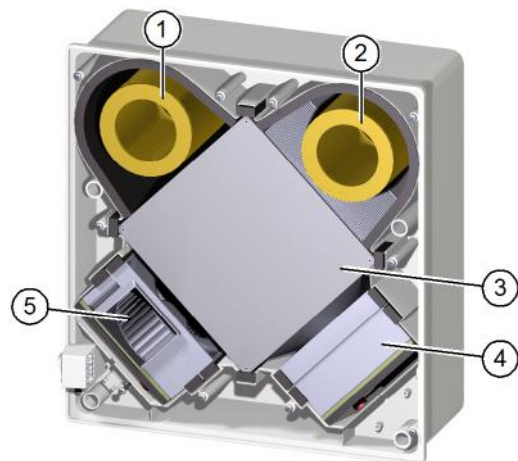

Fig. 8: Components for air exchange

5.2.2 How the cross-flow plate heat exchanger works

The warm extract air (item 5 in Fig. 9) drawn in from the interior is routed through the chambers of the cross-flow plate heat exchanger (item 1 in Fig. 9) and heats them.

The cooled extract air is carried to the outside as exhaust air (item 3 in Fig. 9).

At the same time, the cold outdoor air that is drawn in (item 2 in Fig. 9) is routed through the chambers of the cross-flow plate heat exchanger, which are separate from the extract air, and is heated. The separate chambers prevent the outdoor air and extract air from mixing.

The heated outdoor air is routed into the interior as supply air (item 4 in Fig. 9).

Item	Designation
1	Cross-flow plate heat exchanger
2	Outdoor air
3	Exhaust air
4	Supply air
5	Extract air

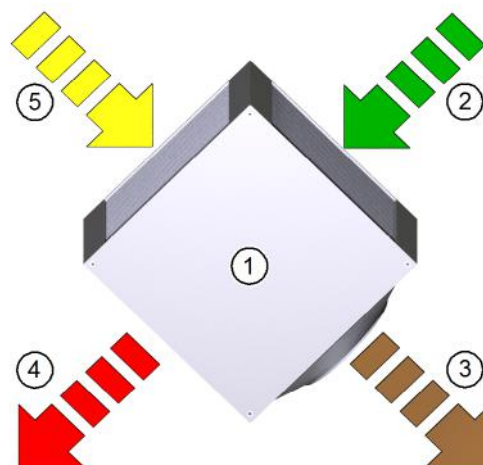

Fig. 9: How the cross-flow plate heat exchanger works

6 Rules for correct usage

6.1 General

- ▶ Run the ventilation unit in continuous operation. The constant ventilation creates a good and healthy atmosphere in the room.
- ▶ Adapt the air flow through the ventilation unit to take account of the air load created by cooking, washing, ironing, visitors, showers, sauna, etc.
- ▶ Set the ventilation unit so that the relative humidity ranges between 40 % and 65 %. People feel most comfortable within this range.

6.2 Operation in high atmospheric humidity

NOTE

- ▶ In the summer months, ventilate cellars and similar rooms only during the night. Otherwise condensation from the atmospheric humidity can cause damage due to damp on the cold walls.

6.3 Operation at cold times of year

NOTE

- ▶ During cold times of year, run the ventilation unit in continuous mode.
 - Energy-saving motors and an innovative controller ensure a very low power consumption, even in continuous mode (roughly 3.8 W at the lowest level).
 - Continuous removal of moisture from the interior is only guaranteed in continuous mode.
 - The condensate is only routed outside in continuous mode.
- ▶ In the following cases, run a 10-minute ventilation burst at maximum power level:
 - regularly if there is high atmospheric humidity in the interior
 - if you need to switch off the ventilation unit.

This will remove any condensate that is present in the ventilation unit.
- ▶ Maintain the temperature in bedrooms at 16 °C to 18 °C or more. This temperature is also more healthy for the people in the bedrooms. Do not run the ventilation unit at room temperatures below 15 °C, and particularly not at low external temperatures below -5 °C. Otherwise the ventilation unit will constantly activate the frost protection function or switch off altogether. The higher the interior temperature, the bigger the buffer for operating the ventilation unit and for heat recovery.

6.4 Filter

- ▶ Never run the ventilation unit without filters.
- ▶ Always use genuine Meltem filters. These are precisely matched to your M-WRG ventilation units, ensure minimal pressure losses and will ensure a long service life from your ventilation units.
- ▶ For hygiene reasons, replace both filter cartridges at least 1x every year, ideally before the period of cold weather.
- ▶ Observe the audible filter change indicator and replace the filters as necessary.

7 Controls on the ventilation unit

Item	Designation
1	Mains switch I = Ventilation unit "On" O = Ventilation unit "Off"
2	Stepping switch for 3 power levels: Power level I = 15 m ³ /h Power level II = 30 m ³ /h Power level III = 60 m ³ /h Intensive ventilation level: Switching sequence I-II-I = 100 m ³ /h (15 min)

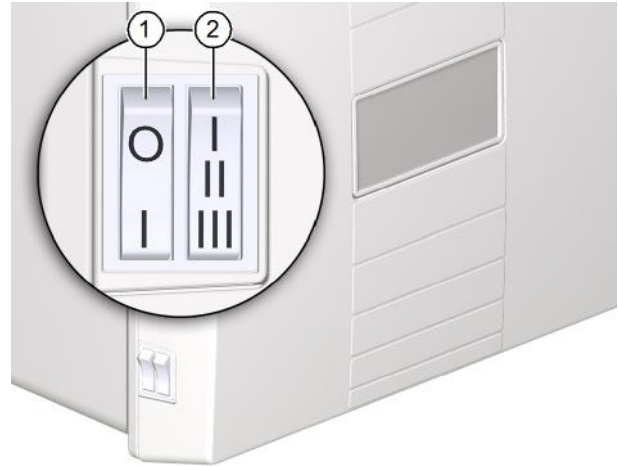

Fig. 10: Controls on the ventilation unit

8 Starting up

8.1 Check ventilation unit before switching on for first time

- ▶ Check the ventilation unit for damage.
- ▶ Check that the openings for extract air and supply air are unobstructed.

8.2 Switch on the ventilation unit

- ▶ Switch the ventilation unit on at the mains switch (item 1 in Fig. 10 on page 16).
After approx. 10 seconds, the air flaps on the extract air and supply air openings open.

8.3 Check position of air flaps

NOTE

- ▶ Check the position of the air flaps (see Fig. 11 and Fig. 12) on the extract air and supply air openings.
 - Both air flaps will be closed if the ventilation unit is switched off or without power (see item 1 in Fig. 11).
 - Both air flaps open when you switch on (see item 1 in Fig. 12).

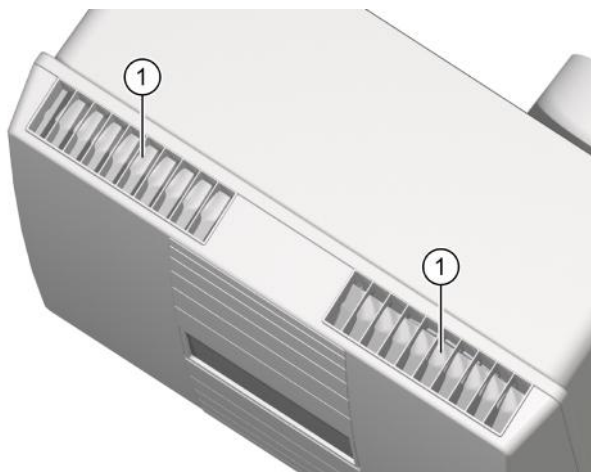

Fig. 11: Air flaps closed

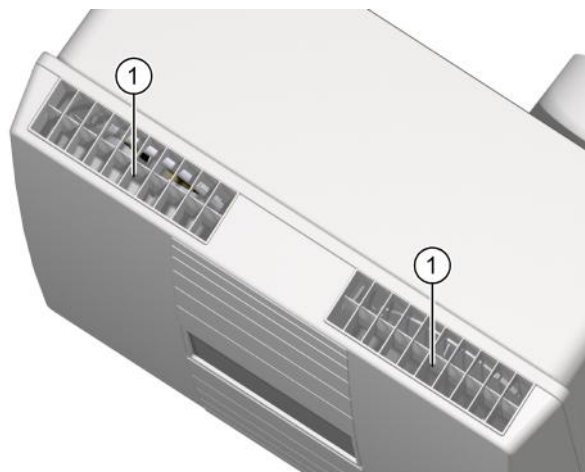

Fig. 12: Air flaps open

NOTE

If the air flaps do not open fully after switching on for the first time or after a longer stoppage, follow the steps below:

- ▶ Switch the ventilation unit off.
- ▶ Wait at least 15 seconds.
- ▶ Switch the ventilation unit on again.

The air flaps should open fully. If this is not the case, repeat the above steps.

9 Operating the ventilation unit

9.1 Set ventilation level on stepping switch

Using the stepping switch (item 2 in Fig. 10 on page 16) for three power levels and a time-limited intensive ventilation level, you can select the required air flow.

Switch position	Air flow
I	15 m ³ /h
II	30 m ³ /h
III	60 m ³ /h
Switching sequence I-II-I	100 m ³ /h(intensive ventilation level, 15 min)

NOTE

- Selecting switching sequence I-II-I on the stepping switch within two seconds results in 15 minutes of intensive ventilation at maximum power level (100 m³/h). The ventilation unit then resumes operation at the previously set ventilation level.
- You can cancel intensive ventilation while it is running by selecting switching sequence I-II-I again.

9.2 Frost protection function

The ventilation unit is equipped with a frost protection function. In low outdoor temperatures, the ventilation unit automatically switches to frost protection mode.

- Do not switch the ventilation unit off in the winter. Note section „6 Rules for correct usage“ on page 14.

How it works (extract from the national technical approval Z-51.3-138):

To prevent the heat exchanger from icing up, there is a temperature sensor fitted on the exhaust air side for constantly monitoring the temperature. If the exhaust air temperature drops below 2 °C, the motor controller gradually changes the supply air and/or extract air volume flow according to the fan level so that the proportion of extract air is increased. This causes the temperature to rise on the exhaust air side. When an exhaust air temperature of 4 °C is maintained for a period of 3 minutes, the unit switches back to the previous operating state. If a temperature of 2 °C is not achieved on the exhaust air side, despite increasing the proportion of extract air, e.g. because the room has cooled down, the extract air and supply air fans are switched off. As soon as a value of 4 °C is identified at the exhaust air temperature sensor, Ventilation mode is resumed at the fan level that was set before it was switched off.

10 Filter maintenance

The level of soiling of the round filter cartridges is automatically monitored by the ventilation unit. A pending filter change is signalled audibly roughly 2 to 3 weeks in advance.

As the time for the filter change approaches, the intervals between the audible warnings shorten. The filters must be changed when the warning signal occurs every hour and lasts for one second. This long warning period allows the user to order replacement filters in good time. No tools are needed to change the filters.

10.1 Choice of filter

There are several filter classes available for the M-WRG-S ventilation unit:

Part no.	Designation	Filter type	Filter class	Application
5571	M-WRG-FS	Standard filter (for supply air and extract air)	G4	Normal use
5572	M-WRG-FA	Allergy filter (for supply air only)	F7	For people with allergies
5573	M-WRG-FK	Activated charcoal filter (for supply air only)	M6	For outdoor air polluted by cars, industry, domestic fuel, etc.

10.2 Ordering filters

Please contact your local dealer for information on ordering filters. You will find the contact details on our website at www.meltem.com (or using the QR code on this page).



Go to
www.meltem.com

10.3 Filter change

NOTE

- ▶ Always replace filters in pairs, at least once per year and ideally before the period of cold weather. The permeability of both filters affects the efficiency and power consumption of the ventilation unit.
- ▶ Always switch the ventilation unit off at the mains switch for the filter change. Otherwise the open air flaps will make it impossible to remove and insert the filter cartridges.

10.3.1 Remove cover from ventilation unit

- ▶ Using both thumbs, press the two latches (item 1 in Fig. 13) on the bottom of the ventilation unit. The cover will come away.
- ▶ At the same time, push your index fingers into the gap between the cover and housing, and lift the cover up from the housing.



Fig. 13: Remove cover from the ventilation unit

10.3.2 Remove filter

- ▶ Turn the filter ring (item 1 in Fig. 14) using the hand grip (item 2 in Fig. 14) anti-clockwise until the arrow on the filter ring (item 3 in Fig. 14) lines up with the arrow at the removal position (item 4 in Fig. 14).
- ▶ Pull the filter ring together with the extract air filter out of the ventilation unit.
- ▶ Turn the filter cover (item 6 in Fig. 14) using the hand grip (item 7 in Fig. 14) anti-clockwise until the arrow (item 8 in Fig. 14) on the filter cover lines up with the arrow at the removal position (item 9 in Fig. 14).
- ▶ Pull the filter cover together with the supply air filter out of the ventilation unit.
- ▶ Detach the extract air filter from the filter ring.
- ▶ Detach the supply air filter from the filter cover.
- ▶ Clean the filter ring and filter cover with a damp cloth if they are dirty (see section 11).

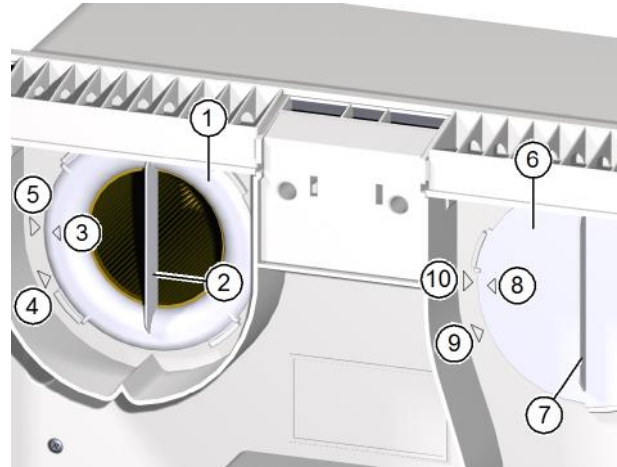

Fig. 14: Remove filter

10.3.3 Insert new filters

- ▶ Carefully guide the extract air filter into the ventilation unit.
- ▶ Make sure that the filter slides into the four retaining tabs (item 1 in Fig. 15) on the back wall of the ventilation unit.
- ▶ Place the filter ring on the extract air filter. Make sure that the filter ring lies flat on the intermediate plate (item 2 in Fig. 15).
- ▶ Make sure that the filter ring is oriented so that the arrow on the filter ring (item 3 in Fig. 14 on page 20) lines up with the arrow for the removal position (item 4 in Fig. 14 on page 20).
- ▶ Turn the filter ring clockwise until the arrow on the filter ring (item 3 in Fig. 14 on page 20) lines up with the arrow for the locking position (item 5 in Fig. 14 on page 20).
- ▶ Insert the new supply air filter. Repeat the steps described for the extract air filter.
- ▶ Check the position of the filter ring and filter cover. The hand grips must be vertical and the arrows on the filter ring and filter cover must line up with the arrows for the locking position (see Fig. 14 on page 20).

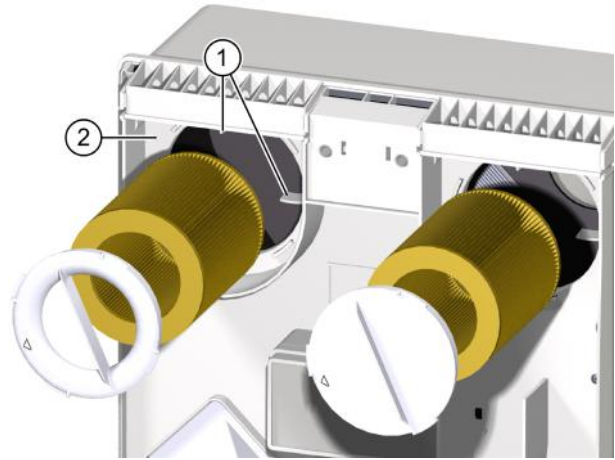

Fig. 15: Insert filter

NOTE

- The ventilation unit will not work as well if the filter ring or filter cover is not inserted correctly.
- Allergy filters and activated charcoal filters may only be used as supply air filters.

10.3.4 Attach cover to ventilation unit

- ▶ Hold the cover (item 1 in Fig. 16) of the ventilation unit with both hands and tilt the top edge of the cover towards the ventilation unit.
- ▶ Insert the tabs (item 2 in Fig. 16) of the cover into the openings (item 3 in Fig. 16) on the top of the ventilation unit.
- ▶ Lightly press the bottom edge of the cover against the ventilation unit until you hear the cover snap in place.

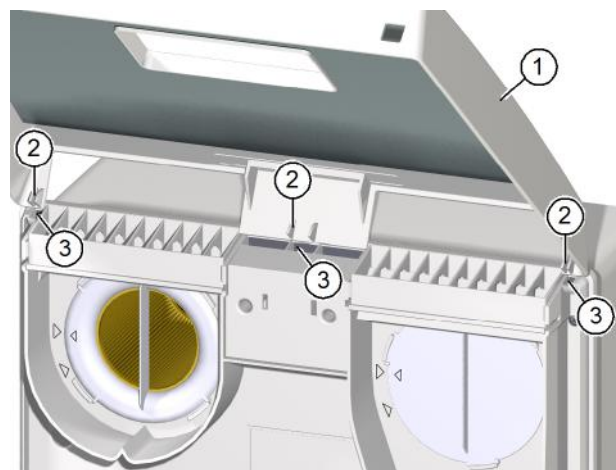

Fig. 16: Attach cover to ventilation unit

11 Cleaning

WARNING

- ▶ Switch off the power to the ventilation unit before cleaning.
- ▶ When cleaning, make sure that no moisture penetrates into the inside of the housing.
- ▶ Never use a high pressure cleaner, steam cleaner or steam jet.

The ventilation unit is made of high quality plastic and requires little care.

- ▶ Wipe the outer surfaces from time to time with a soft, damp cloth. Use mild soapy water. A commercially available plastic cleaner can be used for particularly stubborn dirt.

NOTE

- ▶ Never use acidic, corrosive or abrasive cleaning agents.

12 Troubleshooting

Error	Cause	Remedy
Ventilation unit is not running	Ventilation unit is in safe mode after an EMC fault	Switch the ventilation unit off, wait 15 seconds, then switch on
	Installation error	Have the wiring checked by a qualified electrician
	Faulty switch, motor or controller	Check by a qualified electrician
Air flaps do not open after switching on	After a long stoppage or when starting up for the first time, the servomotor is not powered by the electronic circuit.	Switch the ventilation unit off and on again
	Air flap range of motion is blocked by foreign bodies (plaster, polystyrene, etc.)	Carefully remove the foreign bodies, remove the cover if necessary (see „10.3.1 Remove cover from ventilation unit“ on page 20)
Ventilation unit starts to chirp at intervals	Filter is dirty	Change the filter (see „10.3 Filter change“ on page 19)
The ventilation unit frequently activates the frost protection function		

Space for notes





We have checked the content of this publication for conformity with the unit described in it. There may nevertheless still be differences, so we cannot guarantee complete accuracy.

The information in this publication is regularly checked and any necessary corrections are made in the subsequent editions.

Copyright © Meltem Wärmerückgewinnung GmbH & Co. KG

We reserve the right to make changes.

Meltem Wärmerückgewinnung GmbH & Co. KG

Am Hartholz 4
D-82239 Alling
Germany

Tel. +49 (0)8141 404179-0
Fax +49 (0)8141 404179-9
Internet: www.meltem.com
Email: info@meltem.com



Go to
Meltem download area